

Interconnection Standards for KCP&L and Westar Energy, Evergy Companies

Westar

Residential-Customer Owned Generation Schematic Diagram

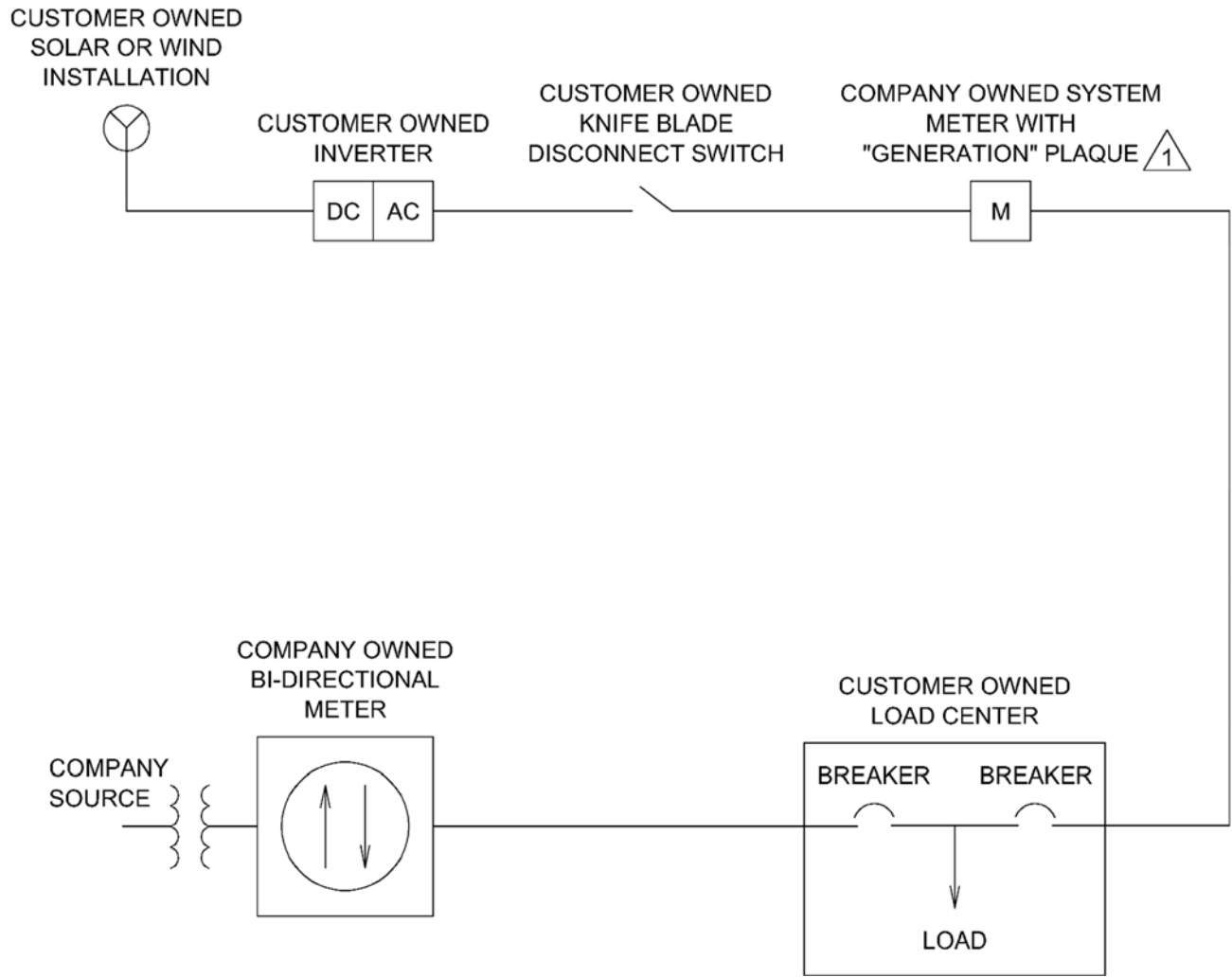

Notes:

1. See section 2 and 3 of the ESS for general metering information and installation diagram. Meter must be accessible to Company employees.
 2. Equipment shall be installed and labeled in accordance with the NEC and all applicable requirements for the serving electric utility company and of the local authority having jurisdiction.
 3. Equipment shall be listed, tested and marked to withstand the available short circuit current.
 4. When generation is attached to the same structure as Company's service wire and meter, both meters should be located in close proximity to each other (suggestion: within 5 feet). For ground-mounted generation, meter to be typically installed near generation site. When generation is installed on a separate structure as Company service wire, the generation meter can be on that separate structure provided it is accessible to The Company.
 5. For 3 phase generation use gang operated switch.
 6. Knife blade switch is for visual open/close.
 7. If meter is moved or modified, it needs to be brought up to current Company standards
- * Any request not compliant with this drawing requires Company engineering approval.

Residential-Customer-Owned Generation Meter Pole and 9.5 KVA and Above Schematic Diagram

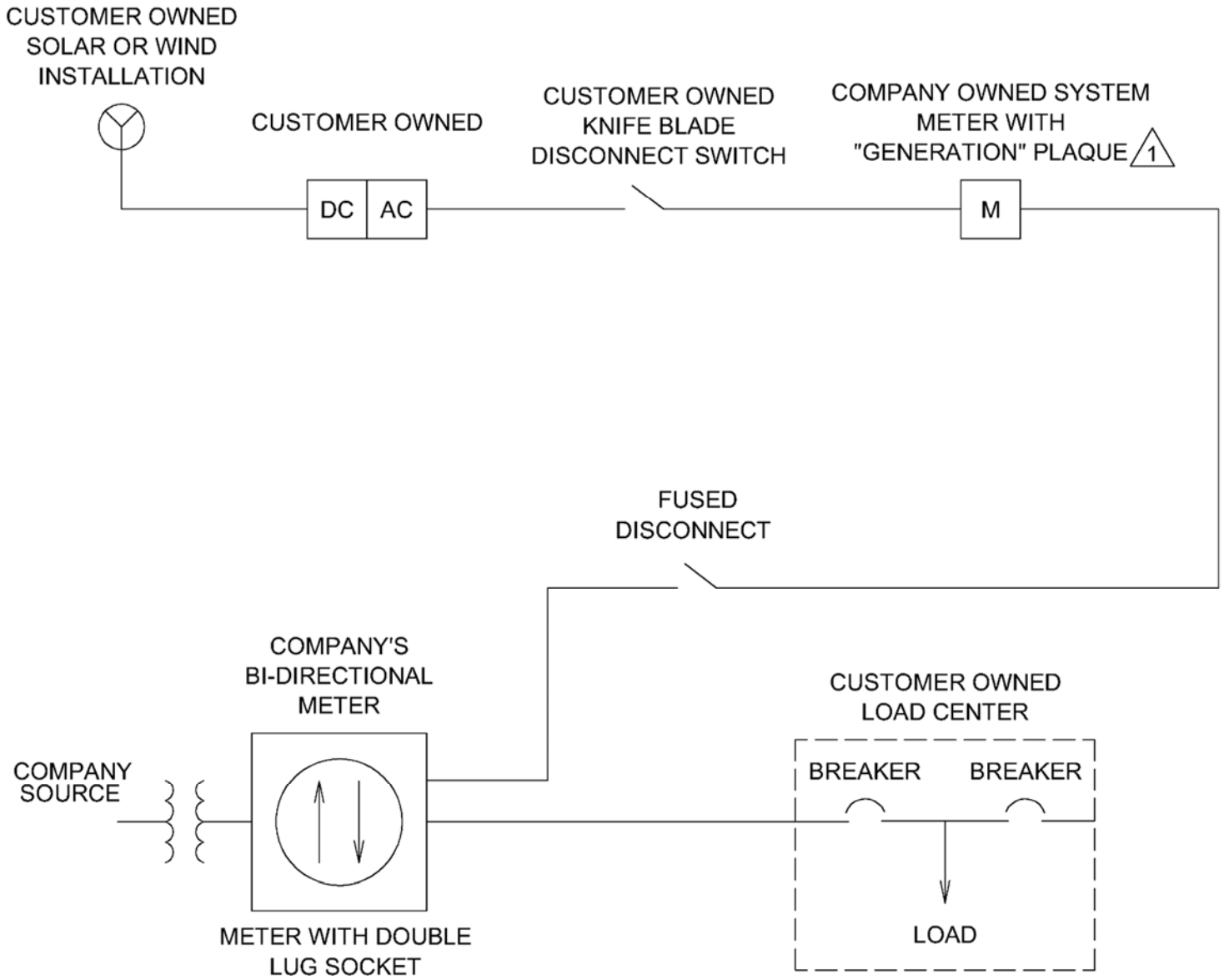

Notes:

1. See section 2 and 3 of the ESS for general metering information and installation diagram. Meter must be accessible to Company employees.
2. Equipment shall be installed and labeled in accordance with the NEC and all applicable requirements for the serving electric utility company and of the local authority having jurisdiction.
3. Equipment shall be listed, tested and marked to withstand the available short circuit current.
4. When generation is attached to the same structure as The Company's service wire and meter, both meters should be located in close proximity to each other (suggestion: within 5 feet). For ground-mounted generation, meter to be typically installed near generation site. When generation is installed on a separate structure as Company service wire, the generation meter can be on that separate structure provided it is accessible to The Company.
5. For 3 phase generation use gang operated switch.
6. Knife blade switch is for visual open/close.
7. If meter is moved or modified, it needs to be brought up to current Company standards
- * Any request not compliant with this drawing requires Company engineering approval.

Commercial Customer- Owned Generation Schematic Diagram

CUSTOMER OWNED
SOLAR OR WIND
INSTALLATION



CUSTOMER OWNED
INVERTER

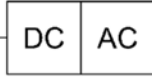

CUSTOMER OWNED
KNIFE BLADE
DISCONNECT SWITCH



COMPANY OWNED SYSTEM
METER WITH
"GENERATION" PLAQUE 

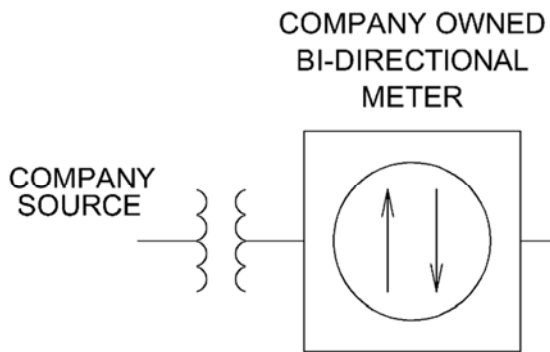

CUSTOMER OWNED
DISCONNECT SWITCH



CUSTOMER OWNED
LOAD CENTER

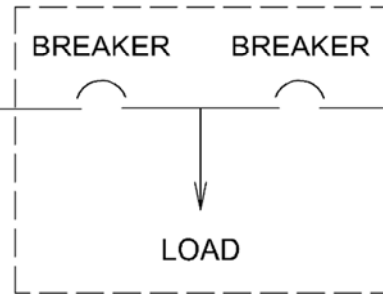

Notes:

1. See section 5 of the ESS for meter installation diagram. Meter to be accessible to Company employees.
 2. Equipment shall be installed and labeled in accordance with the NEC and all applicable requirements for the serving electric utility company and of the local authority having jurisdiction.
 3. Equipment shall be listed, tested and marked to withstand the available short circuit current.
 4. When generation is attached to the same structure as The Company's service wire and meter, both meters should be located in close proximity to each other (suggestion: within 5 feet). For ground-mounted generation, meter to be typically installed near generation site. When generation is installed on a separate structure as Company service wire, the generation meter can be on that separate structure provided it is accessible to The Company.
 5. For 3 phase generation use gang operated switch.
 6. Knife blade switch is for visual open/close.
 7. If meter is moved or modified, it needs to be brought up to current Company standards
- * Any request not compliant with this drawing requires Company engineering approval.

Commercial Customer-Owned Generation For systems 1MW and Above Schematic Diagram

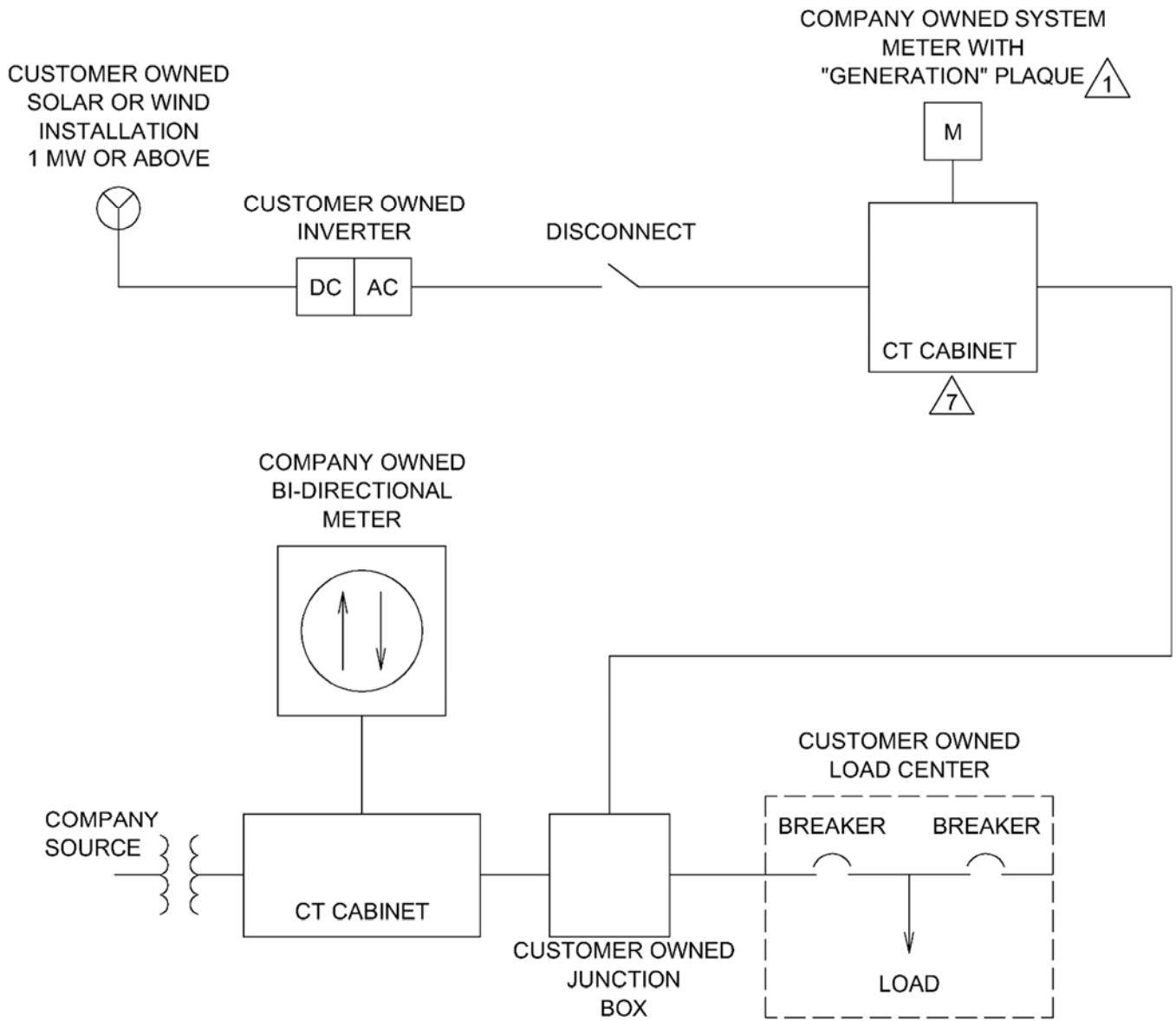

Notes:

1. See section 5 of the ESS for meter installation diagram. Meter to be accessible to Company employees.
 2. Equipment shall be installed and labeled in accordance with the NEC and all applicable requirements for the serving electric utility company and of the local authority having jurisdiction.
 3. Equipment shall be listed, tested and marked to withstand the available short circuit current.
 4. When generation is attached to the same structure as The Company's service wire and meter, both meters should be located in close proximity to each other (suggestion: within 5 feet). For ground-mounted generation, meter to be typically installed near generation site. When generation is installed on a separate structure as Company service wire, the generation meter can be on that separate structure provided it is accessible to The Company.
 5. For 3 phase generation use gang operated switch.
 6. Knife blade switch is for visual open/close.
 7. If meter is moved or modified, it needs to be brought up to current Company standards
- * Any request not compliant with this drawing requires Company engineering approval.

KCP&L

Parallel Generation

No customer shall operate or permit operation of electric generating equipment in parallel with electric service supplied by the Company except as may be permitted under the Customer's service agreement.

The Company will supply, own, and maintain all necessary meters and associated equipment utilized for billing. In addition, and for purposes of monitoring Customer generation and load, the Company may install, at its expense, load research metering. The Customer shall supply, at no expense to the Company, a suitable location for meters and associated equipment used for billing and for load research. Such equipment shall be accessible at all times to Company personnel.

The Customer shall furnish, install, operate, and maintain in good order and repair, without cost to the Company, such relays, locks, seals, breakers, automatic synchronizer, a disconnect device, and other control and protective devices as shall be designated the Company as being required suitable for the operation of the generator in parallel with the Company's system.

The Customer shall provide a manual disconnect switch which shall be under the exclusive control of the Company. This manual switch must have the capability to be locked out by Company personnel to isolate the Company's facilities in the event of an electrical outage on the Company's transmission and distribution facilities serving the Customer. The Customer must also provide an isolating device which the Customer has access to and which will service as a means of isolation for the Customer's equipment during any qualifying facility maintenance activities, routine outages or emergencies. The Company shall give notice to the Customer before a manual switch is locked or an isolating device used, if possible and otherwise shall give notice as soon as practicable after locking or isolating the Customer's facilities.

The Customer shall notify the Company prior to the initial energizing and start-up testing of the Customer-owned generator, and the Company shall have the right to have a representative present at said test.

The Company may require a special contract for conditions related to technical and safety aspects of parallel generation.

The facility shall meet all requirements of NEC code article 705.

If you have questions, please contact the Customer Contact Center.

Net Metering

The Company shall provide information related to interconnection (net metering) upon customer request. If the Customer wishes to apply for interconnection to the Company's electrical system, the Customer shall complete sections A – D of the net metering facilities application and attach plans and specifications of the installation. The application, along with attached plans, shall be submitted to the following address. They shall be submitted to the following address:

KCP&L
ENERGY SOLUTIONS
P.O. BOX 418679
KANSAS CITY, MISSOURI 64105
Phone: 816-242-5971

The Customer will be provided with an approval or denial of this application. For Customer generators greater than 10kW, the Company shall provide a decision within ninety (90) days. For Customer generators 10kW or less the Company shall provide a decision within thirty (30) days or less. If the application is denied, the Customer will be provided reason(s) for denial. If this application is approved and signed by both the Customer and Company, it shall become a binding contract and shall govern the Customer's relationship with the Company.

The Company interconnection diagrams are located in the drawing section. Please refer to drawings NM-101 and NM-102.

Net Metering-Load Side Interconnection

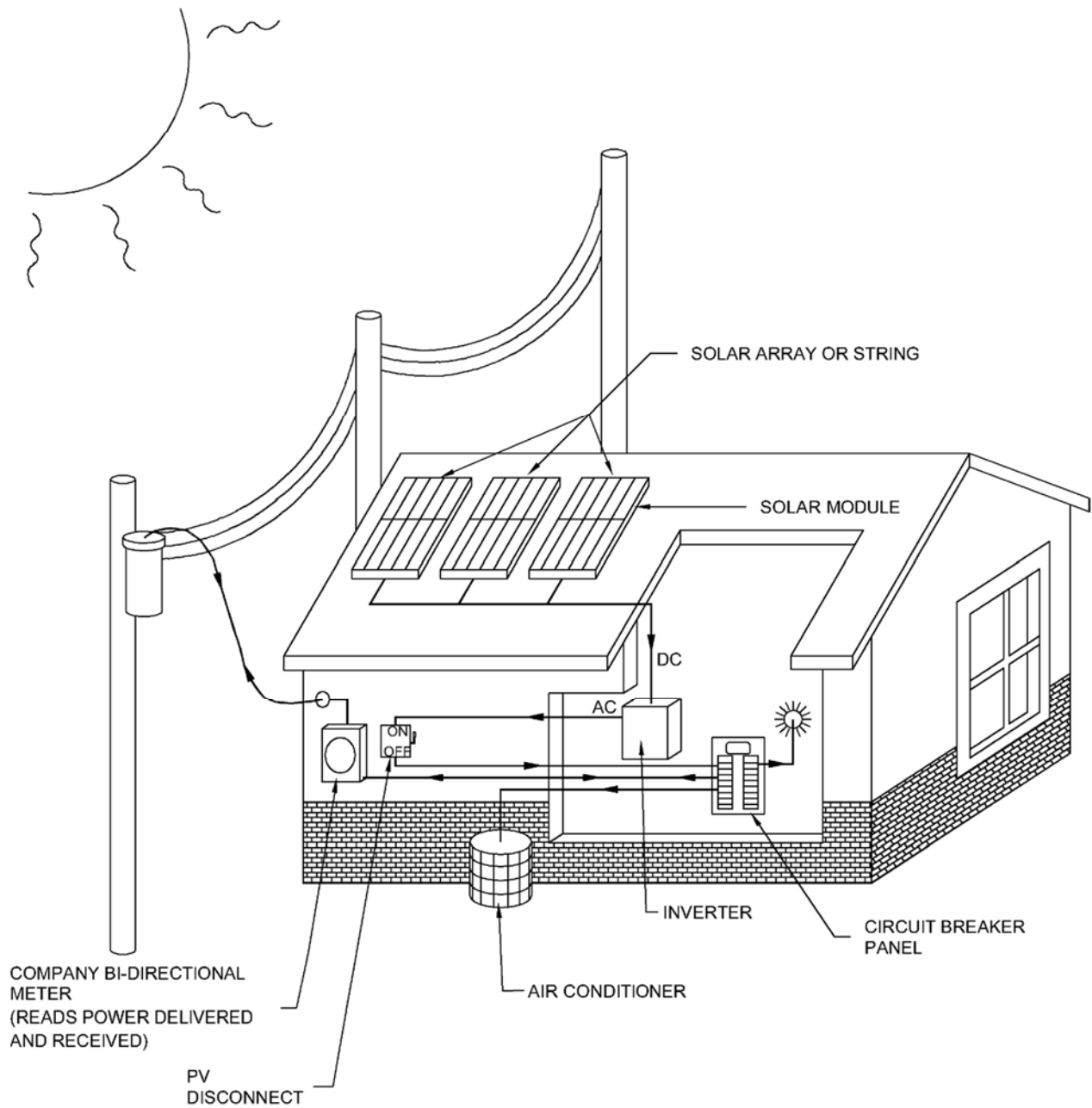

Net Metering-Line Side Interconnection

